

GEO231, February 24, 2011

Today's class will consist of three separate parts:

- 1) Introduction to working with a compass
- 2) Continued work with spreadsheets
- 3) Introduction to surfer software

Your work from these three exercises will be due **Thursday, March 3** at class time.

Part I: Compass work introduction (20 pts.)

A (4 pts.): Understanding Magnetic declination:

A compass measures the orientation of magnetic fields. As long as you are away from metal objects, electrical wires, or strong geologic magnetic anomalies (usually not a problem except in specific areas), the dominant magnetic field will be that generated by earth itself. This field is thought to be set up by currents produced through convection in the earth's liquid outer core, where iron- and nickel-bearing material rotate around the inner core. The orientation of earth's magnetic field is useful information for geologists because "magnetic north," which is the direction in which your compass needle will point in earth's magnetic field (toward the "magnetic north pole", is usually very close to true north (the direction towards the geographic north pole, defined by the axis of earth's rotation). The direction towards the geographic north pole is a useful reference against which to define recorded measurements of direction – any direction can be recorded in terms of the angle difference between that direction and geographic north, and any person reading that measurement later on will know exactly the direction that the writer was talking about. A compass takes advantage of the close correspondence between true and magnetic north.

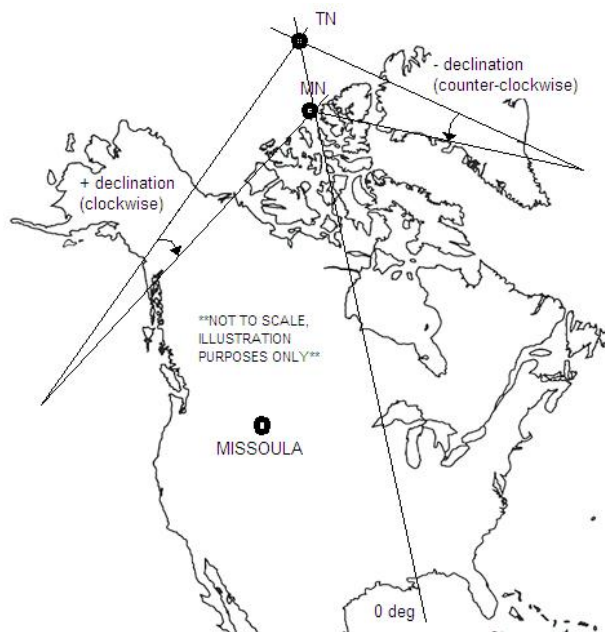

Things are complicated by the fact that the magnetic north pole is not actually located at the geographic North Pole but someplace under northern Canada. So while a good compass can be a reasonably precise instrument, its uncorrected readings will not necessarily be accurate. But since we know where the magnetic north pole is, we can apply a correction to the raw compass readings to produce measurements of direction relative to geographic north. This correction is called the declination. Declination is listed as the angle of rotation from the direction of true north to the direction of magnetic north, with clockwise being positive.

Magnetic declination varies from point to point. Every good topographic map should have a symbol like this the one to right (copied from the USGS 1:24,000 scale Crater Lake topographic sheet, north of Missoula near Bigfork MT), showing the relationship between “up” on the map (the UTM grid line at the center), geographic north (slightly to the left in this example), and magnetic north (slightly to the right in this example). The magnetic declination would be difference between GN and MN, in this case:

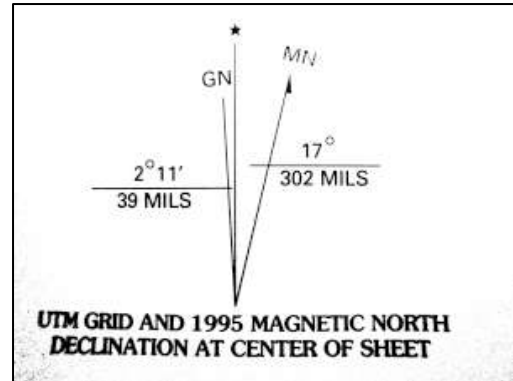

$$2^{\circ}11' + 17^{\circ} = 19^{\circ}11'$$

To make matters even more complicated, the location of the magnetic north pole shifts over time, so that declination is always slowly changing. The figure on the left shows the wander of the magnetic north pole over the past 400 years. Since many USGS topographic maps were made decades ago, it’s always a good idea to check the current declination for your location. There is a government website which allows you to do enter a set of latitude and longitude coordinates (or a zip code) and a date, and will calculate the declination at that point at that for you:

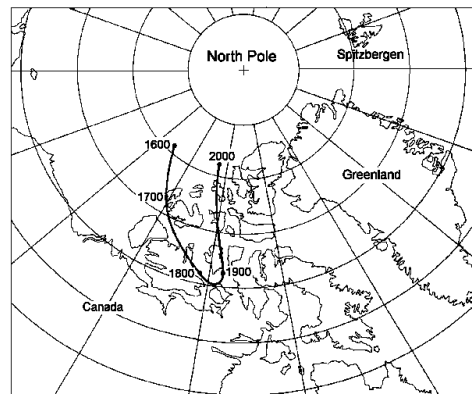

<http://www.ngdc.noaa.gov/geomagmodels/struts/calcDeclination>

Questions (1 pt. each):

- 1) If you were to stand in the middle of the crater lake sheet, should your compass needle be pointing west of north, straight north, or east of north? The USGS declination symbol for this sheet is shown above.
- 2) If you were to travel to the east coast of North America at the same longitude as the Crater Lake sheet, would you expect the compass needle to point west of north, straight north, or true north?
- 3) If you were to travel a few hundred miles south from the Crater Lake sheet but remain at the same longitude, would you expect the declination to be higher or lower than at crater lake?
- 4) Visit the declination calculator website and find the present declination for Bigfork, MT (zip code 59911, very close to the Crater Lake sheet). What is the declination, and has it increased or decreased since the Crater Lake sheet was produced?

B (16 pts.): Reading a compass: On the next four pages are four sets exercises involving hypothetical compass readings and settings. The compass shown is a brunton pocket-transit type without a rotating bezel. Answer each of the questions presented.

Part 1: Below are 4 hypothetical compass readings for a location in which the magnetic declination is 0°. Next to each of the compasses, specify the bearing for the compass in the orientation shown.

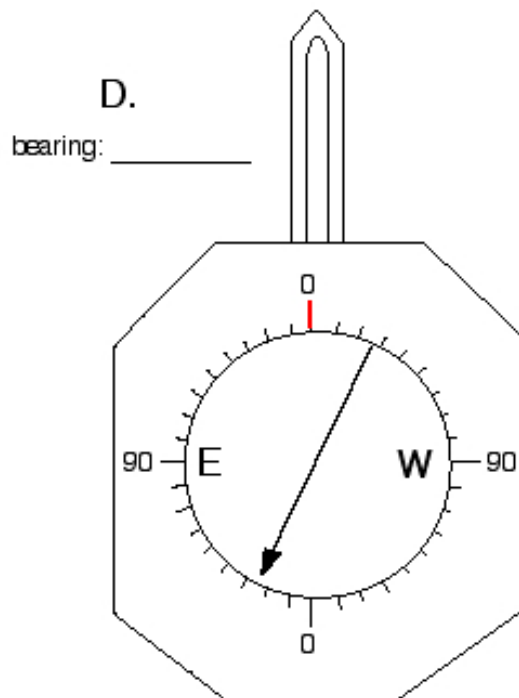
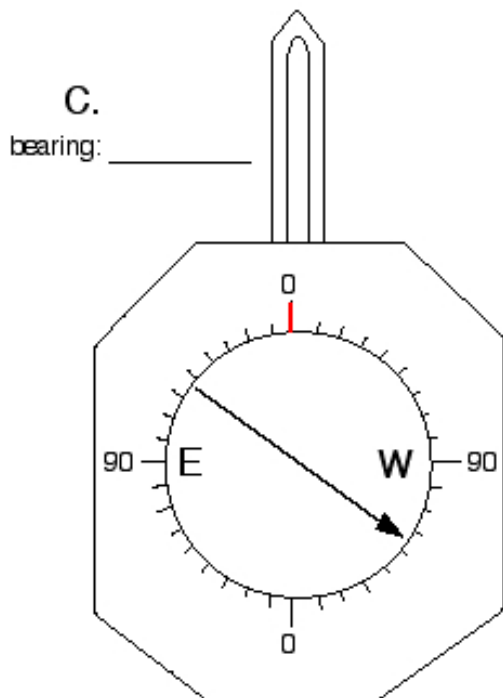
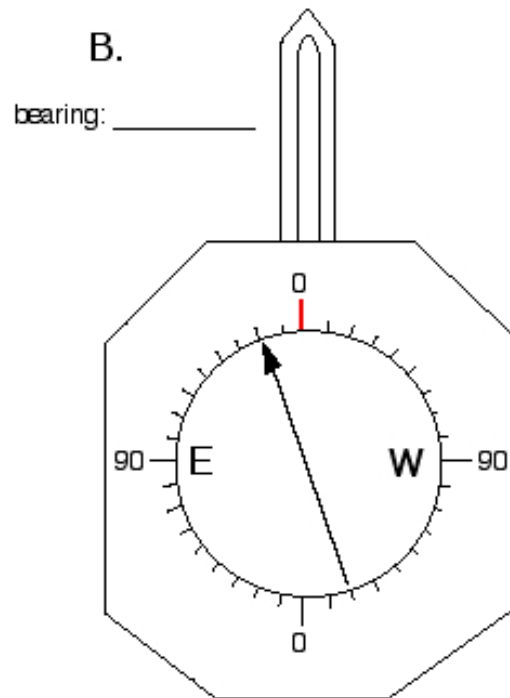
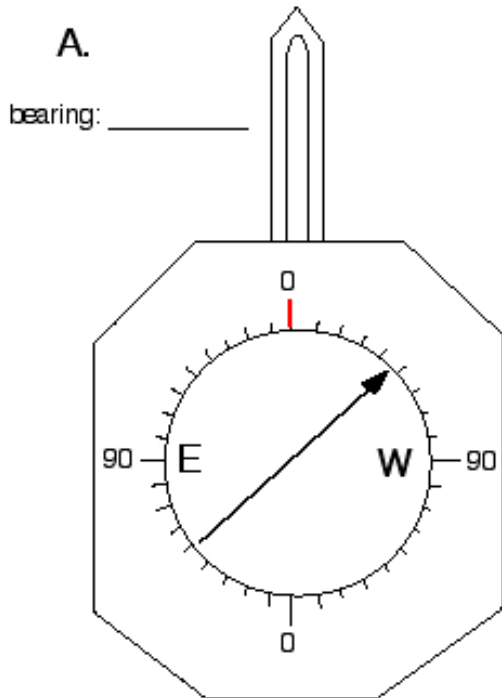

Part 1B: Here are 4 more hypothetical compass readings for a location with 0° magnetic declination. Next to each of the compasses, specify the bearing for the compass in the orientation shown.

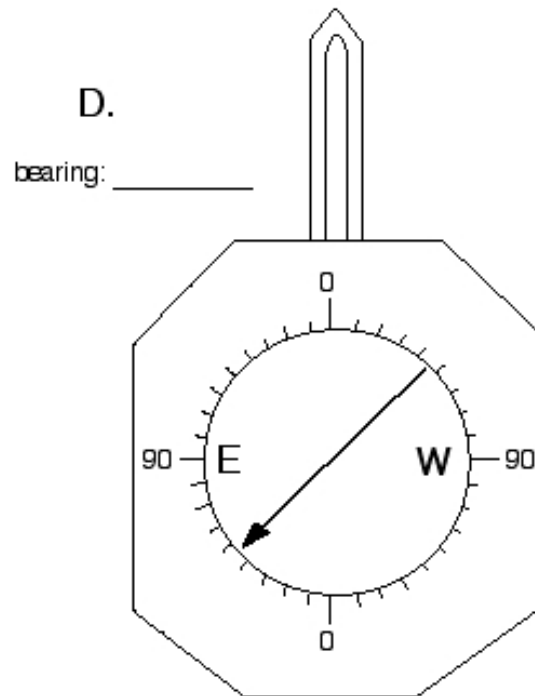
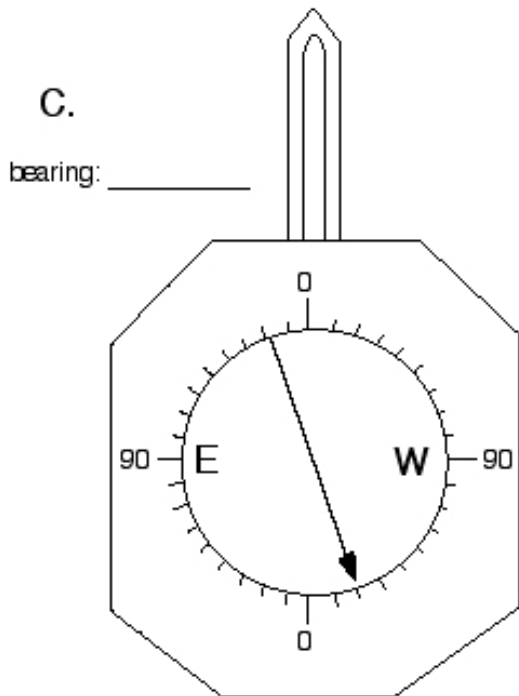
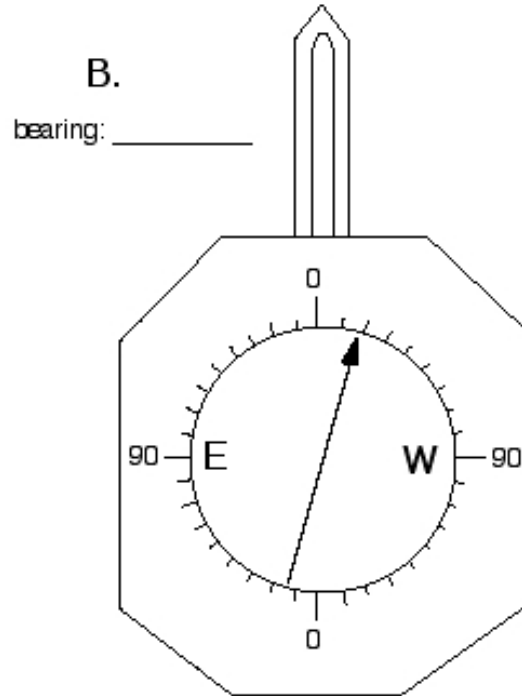
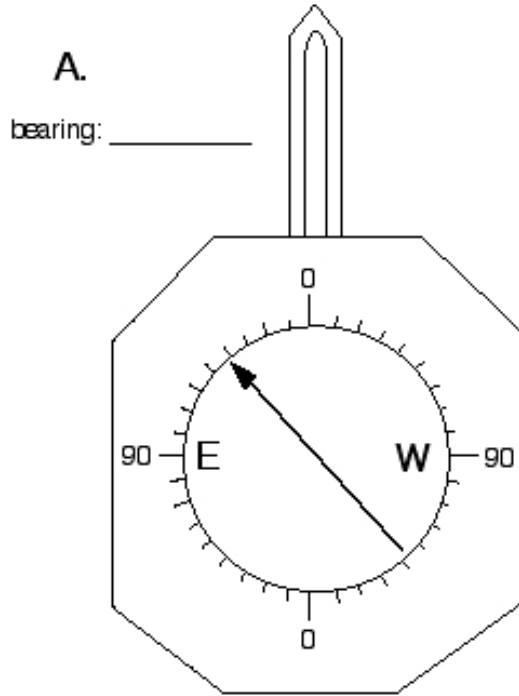

Part 2: Below are 4 hypothetical compass readings for a location in which the magnetic declination is about 19° east. (That is, magnetic north is about 19° east of true north, similar to our situation here in Missoula). Next to each of the compasses, specify the bearing for the compass in the orientation shown.

A.

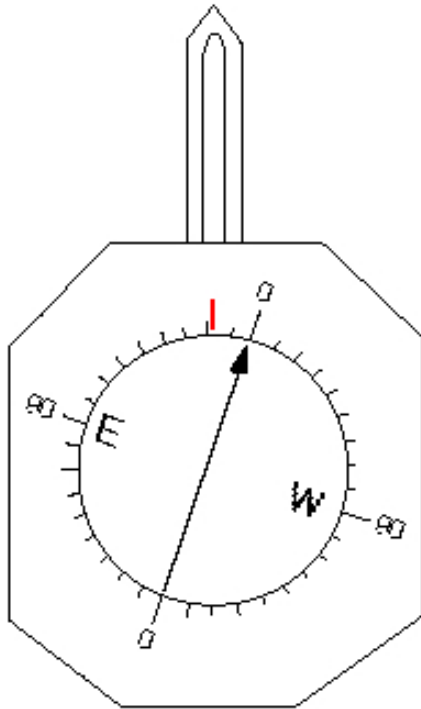

B.

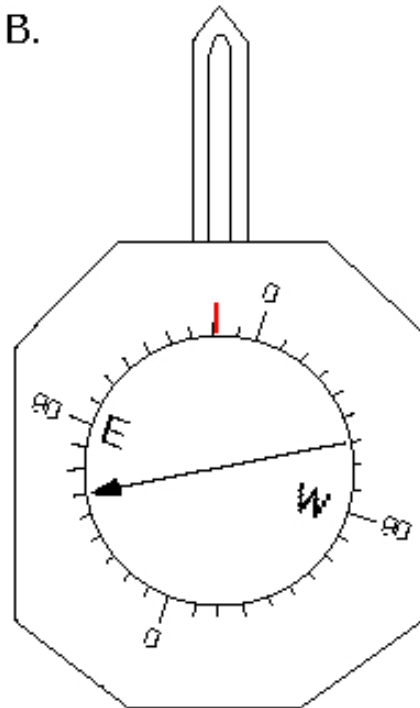

C.

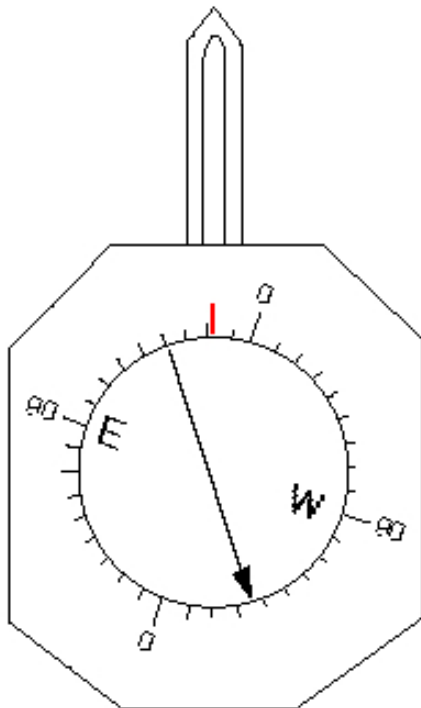

D.

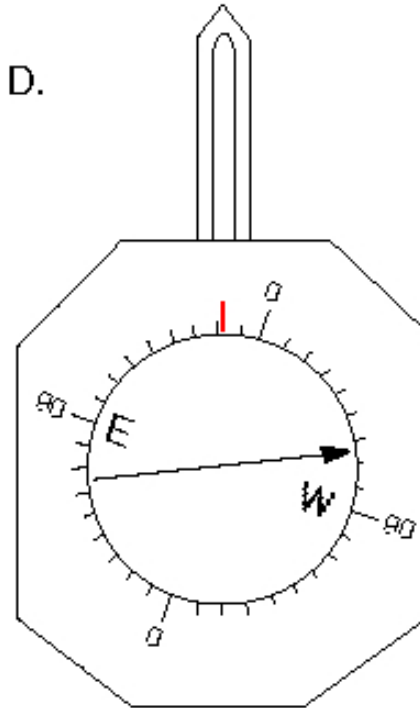

Part 3: Below are four compass faces. Each is set to a different magnetic declination. For each compass, specify the magnetic declination in terms of its magnitude (how many degrees?) and its direction (is magnetic north east or west of true north?).

A.

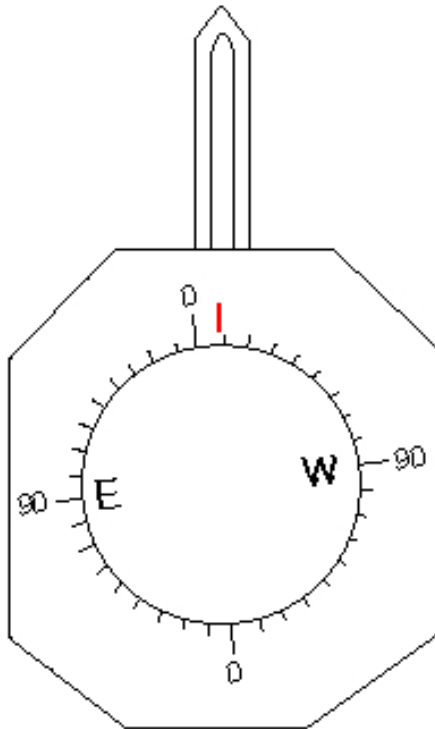

B.

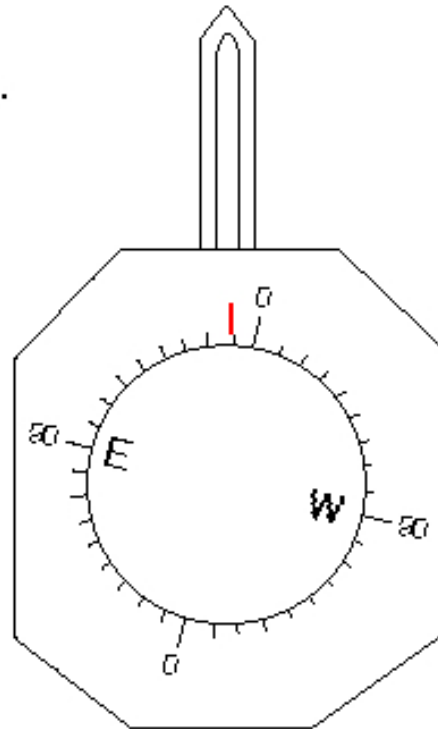

C.

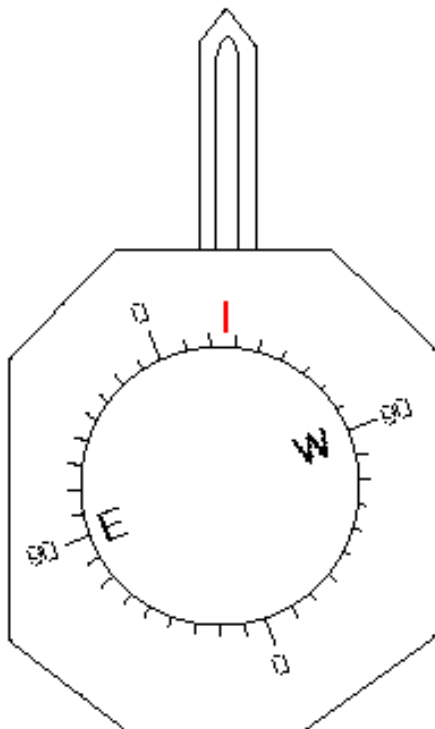

D.

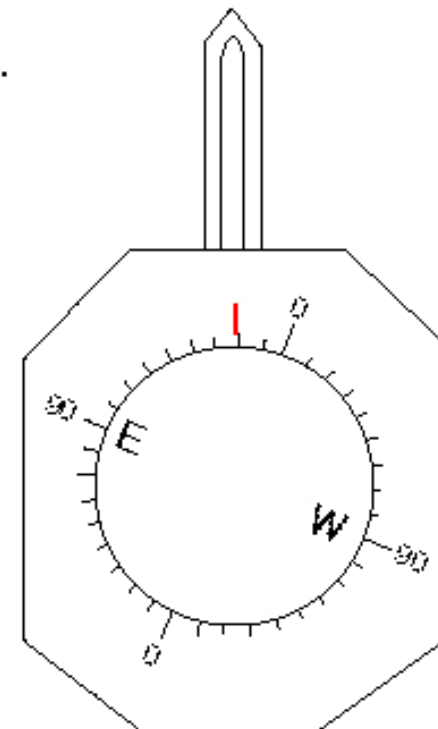

Part II) Processing total station northing, easting, and elevation data using excel (10 pts.) : The main goal of this assignment is to create a post map of northing and easting data from a laser survey of a field study site. The post map you will create will show the X-Y (northing-easting) coordinates of all collected data points. Next week, we'll add the Z (elevation) data to this map to create a topographic map of this same data set.

Here are the steps to follow:

A) Download the file Laird03.txt, on the G230 website. These are data from a 2002 total station shoot I conducted on Laird Creek near Darby. The data are in four columns: the A column contains the identification number for each shot; the B column contains the northing value for that shot; the C column contains the corresponding easting value; and the D column contains the elevation value for that shot.

C) Using the “chart wizard” in excel, graph the northing and easting data on a scatter plot. Be sure to label the axes (including an indication of their scale) and include a title on your map. Hand in this map with the rest of your work for this week.

Part III): Introduction to SURFER software: SURFER is the program we will use to manipulate xyz data from the total station to make a map. SURFER starts with a series of irregularly-spaced spatial data points in 3-D (in other words, x,y,z data) and interpolates between the data to produce a regularly spaced set of x,y,z data on a grid. Using the gridded data, SURFER then is capable of producing a contour map. In some instances, you may be starting with gridded data sets (for example, digital elevation models or DEM's), so it will be possible to contour the data set directly.

SURFER allows you to select among eight different ways to grid a set of ungridded data. These different methods vary in terms of their complexity (i.e., the time it will take the program to do the gridding) and their accuracy. Most geologic data sets can be effectively gridded using either the minimum curvature or kriging methods. The minimum curvature method generates smooth contours and is fast, but can produce boundary effects beyond the limits of the data set. The kriging method is slower but commonly a bit more precise. It tends to generate the best overall interpretation of the data and is the default method in SURFER.

Gridding data using SURFER:

To grid randomly distributed data in SURFER, use Grid/Data from the menu bar. SURFER expects ASCII data organized in columns that are either tab or space delimited. You can put data in this format using Excel, a text editor such as Window's Notepad, or a word processor. You can also type in and organize such data using SURFER's worksheet capability. In the exercise we did last week, you used excel to parse out a set of total station data into x,y,z (easting, northing, elevation) columns — that same method will work here.

When you create a grid file, there are several options to consider. These options, from SURFER's help files, are:

Gridding Methods determine how the original data is interpreted when creating the grid file.

Gridding Options control the Anisotropy and Data Treatment during gridding.

Grid File Formats are the file formats for grid files.

Grid Line Geometry controls the Grid Limits and

Grid Density used for the grid file.

Search Options control the Search Type, Search Rules and Search Ellipse parameters.

Each of these topics is discussed in SURFER's help files.

General steps for gridding data using SURFER:

1. Select Grid/Data from the menu bar and SURFER presents a text box in which you move through your computer's directory structure and click the text file you wish to grid.

2. SURFER then presents its "Scattered Data Interpolation" text box. Indicate which of the columns in your data file has the x, y, and z values you wish to grid, the spacing you wish those data to be gridded at (minimum and maximum values), the gridding method, and the name of the output file. Kriging is not a bad default for gridding most data. Click OK and SURFER grids your data; they are ready to contour, etc.

3. Select Map/Post from SURFER's menu bar. Double click on the data file that contains the points you used to make the contour map, SURFER presents its "Post Map" dialog box. Specify the x and y coordinate columns, change the default symbol, color, font, and the like so it looks good, and click OK. Note: If you want to have different symbols for different data points, you will need to organize your original spreadsheet so the coordinates for each data point type is in separate columns, then post them up separately on your map using SURFER and give each subset a unique symbol in the "post map" dialog box.

4. If you would like to contour your data, select 'New Contour Map' and click navigating to the *.grd file. Once the gridded data are read by the program, another dialog box appears in which you can specify the contour interval and/or fill the contours with different colors. To change the contour interval, click the 'levels' tab, then click 'levels' again and change the 'interval' to the appropriate number. Click OK twice and your map should appear with the contours. Once the contoured data are plotted, you can add a title to your map, a north arrow, a legend, etc. by using the options in the menu bar at the top of the page.

Exercises for this week:

Part I:

1. Download the files FARLIN02. Before saving the files, create a folder entitled "Geology 230" at the desktop level and putting the files into that folder. This file contains data from a total station shoot of an abandoned mine tailings pile in the Pioneer Range of southwestern Montana.

2. Save the file as a text file, using the procedure we learned last week:

a. Open the web page which has the link you want to download.

- b. Right click on the link you want to download.
 - c. In the menu box that opens select the "save target as" option
 - d. If you have not already done so, create a folder entitled "Geology 230" at the desktop level of the HD. Use this folder for all of your work
 - e. Save the file as a text file. Change the extension to .txt, so you can easily identify the file type .
 - f. Start Excel and open the text file you just saved. You will need to set the file type to All Files (*.*)
 - g. The parse dialog box will open. Check out the data set to see how they are delimited and parse the data accordingly.
3. Insert a row at the top of the data set and label the columns 'Point ID', easting, northing, and elevation.
 4. Launch surfer and post your easting and northing data. To do this, pull down the map menu bar and go to post map > new post map, then follow the directions in step 3 of the section "General steps for gridding data using SURFER" above.
 5. To superimpose contours onto your post map, you will first need to grid your data if you have not already done so. Follow step 4 in the section above to grid your data. Use the kriging method.
 6. Add a title, legend, and north arrow to your map and print it out.
 7. Repeat steps 4-6, but use the minimum curvature method for your gridding. Discuss in a paragraph or so the main differences between the two maps. Which seems more precise? Is this precision real or do you think it is artificial? I want to see some critical thinking here, not just a few cursory words.

Part III; continued work with SURFER:

1. Download the file Laird04.txt . This file contains (x,y,z) data for a topographic total station shoot in the Laird Creek drainage near Darby.
2. Grid the data in this file, using SURFER.
3. Create a post map of the data set.
3. Add contours to your post map, using a contour interval of 1 m.
4. Add a title and legend to the map.
5. Re-grid the data using the minimum curvature method and construct a second map complete with title, legend, etc.

Hand in each of your four maps, complete with title, legend, and north arrow. Also hand in your response to the questions in #7 above.